

SPECIFICATIONS

SKU 66908 16" 37cc

Engine	Type	2 Stroke, air cooled
	Rating	1.6 horsepower
	Start	Recoil
Compression		150 PSI
Displacement		37.2 cc
Sound Level		114 dB @ 3 ft.
Fuel	Type	90+octane unleaded gasoline/2-cycle oil
	Fuel/Oil Ratio	40:1
	Capacity	10.5 oz.
Chain Oil	Type	Chain & Bar Oil
	Capacity	7 oz.
Spark Plug	Type	Bosch LD L8RTF or Champion RCJ-7Y
	Gap	0.023" ~ 0.031"
Speed	Idle	3,400 RPM
	No Load	12,500 RPM
Cutting Attachment	16" Oregon® Bar: Model # 6G 516480 91 Sprocket nose and Oregon® Chain: Anti-Kickback standard skip chain Pitch: 3/8" Gauge: 0.050" # of drive links: 57 Model #91P057X (Includes 5/32" dia. round file for sharpening)	

SKU 66909 18" 45cc

Engine	Type	2 Stroke, air cooled
	Rating	2.4 horsepower
	Start	Recoil
Compression		150 PSI
Displacement		45 cc
Sound Level		114 dB @ 3 ft.
Fuel	Type	90+octane unleaded gasoline/2-cycle oil
	Fuel/Oil Ratio	40:1
	Capacity	18.6 oz.
Chain Oil	Type	Chain & Bar Oil
	Capacity	8.5 oz.
Spark Plug	Type	Bosch LD L8RTF or Champion RCJ-7Y
	Gap	0.023" ~ 0.031"
Speed	Idle	3,400 RPM
	No Load	12,500 RPM
Cutting Attachment	18" Oregon® Bar: Model # NG 516481 .325 Sprocket nose and Oregon® Chain: Anti-Kickback standard skip chain Pitch:.325" Gauge: 0.058" # of drive links: 72 Model #21BPX072X (Includes 3/16" dia. round file for sharpening)	

The emission control system for these Chain Saw's Engine is warranted for standards set by the U.S. Environmental Protection Agency. For warranty information, refer to the last pages of this manual.

UNPACKING

When unpacking, make sure that the item is intact and undamaged.

CHAIN SAW COMPONENTS

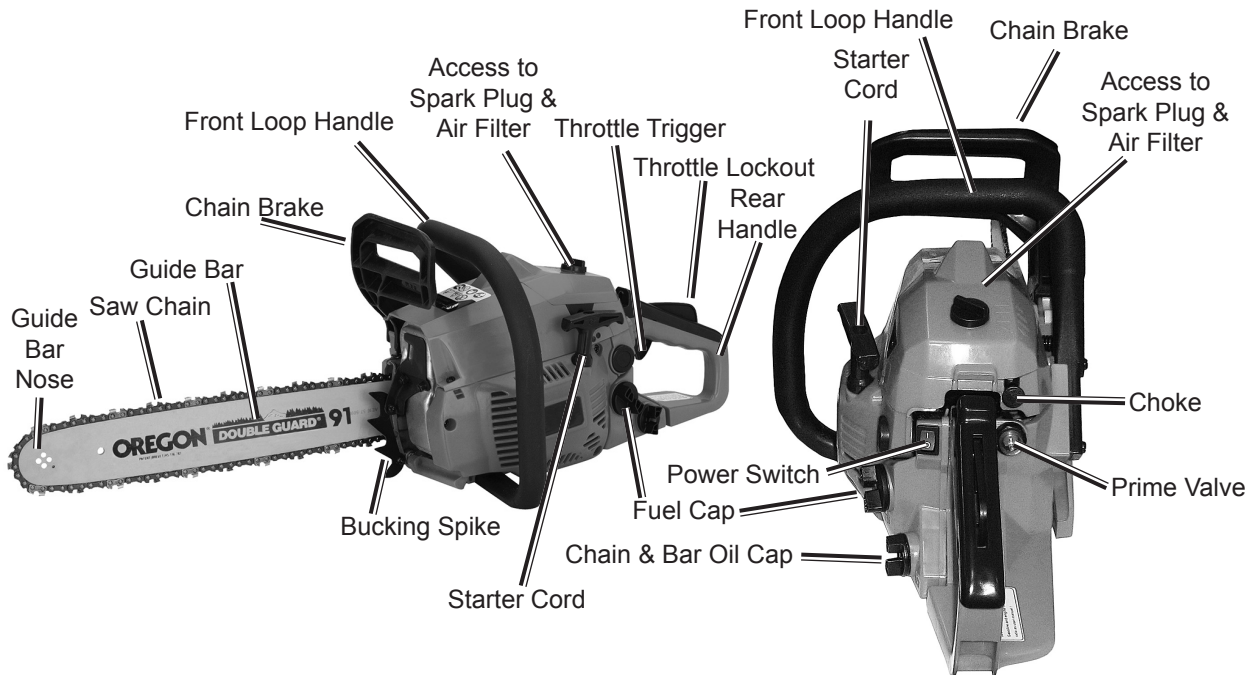

Figure 1 - Model 66908 16" 37cc Chain Saw

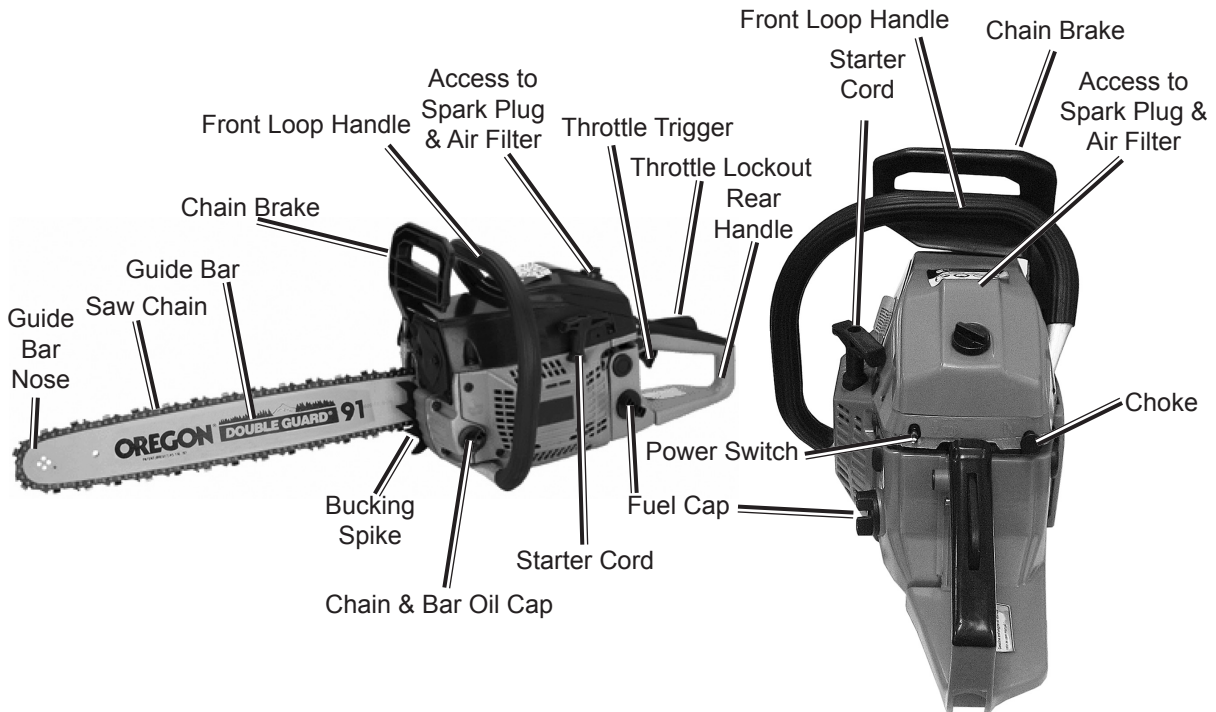

Figure 2 - Model 66909 18" 45cc Chain Saw

1 1/2"

37 cc Gas Chain Saw

Oregon® Chain and Bar with Anti-Kickback

PO# 36932-5199093
DEST: CA OX
C/NO:1-360
QTY: 1PCS
GW: 7.0KG NW:5
MEAS: 46X26X32CM
MADE IN CHINA

Anti Vibration System



- Powerful 37cc two cycle engine
- Reduced kickback sprocket nose guide bar
- Automatic oiler
- 40:1 fuel mix ratio
Fuel not included.

Easy
START-UP
GUIDE
Included

NOT AVAILA
IN CALIFOR

Item 66908

See Chain Saw V

37cc Gas Chain Saw

Item 66908

16"

- Powerful 37cc two cycle engine
- Reduced kickback sprocket nose guide bar with OREGON "S" series 91 low profile chain
- Anti-vibration system

POWERFUL
37cc
Two Cycle
Engine



Oregon® Chain and Bar
with Anti-Kickback

Chain Saw
66908

37cc Gas Chain Saw

Item 66908

16"

- Powerful 37cc two cycle engine
- Reduced kickback sprocket nose guide bar with OREGON "S" series 91 low profile chain
- Anti-vibration system

POWERFUL
37cc
Two Cycle
Engine



Oregon® Chain and Bar
with Anti-Kickback

16"

37cc

Gas Chain Saw

Oregon® Chain and Bar with Anti-Kickback

PO# 34832-0199003
DEST: CACI OXCO BDC
CINOI-368
QTY: 1PCS
GW: 7.8KG NW: 5.2KG
MEAS: 46X26X32CM
MADE IN CHINA

Anti-Vibration System

Easy START-UP



16"

37cc

Gas Chain Saw

Oregon® Chain and Bar with Anti-Kickback

PO# 34832-519903
DEST: CACI OXCO BDC
CINOI-368
QTY: 1PCS
GW: 7.8KG NW: 5.2KG
MEAS: 46X26X32CM
MADE IN CHINA

Anti-Vibration System

Easy START-UP



Anti

DANGER
 To prevent injury and death:
 Always hold guide bar tip to any object,
 and keep release guide bar to move
 forward and backwards.
 Always use both hands during use.
 All adjustments should not use
 oil. Oil should be used.
 Always use proper maintenance bar and
 chain. Always use proper maintenance bar and
 chain. Always use proper maintenance bar and
 chain.

Important Engine Information
 Always read the operator's manual.
 Always use proper maintenance bar and chain.
 Always use proper maintenance bar and chain.
 Always use proper maintenance bar and chain.
 Always use proper maintenance bar and chain.
 Always use proper maintenance bar and chain.
 Always use proper maintenance bar and chain.
 Always use proper maintenance bar and chain.

BEFORE STARTING
 ADD FRESH GAS OIL MIX AND
 ADD 1 OZ. CHAIN OIL
 1. Turn the gas oil mixture of
 2. Remove the gas oil mixture of
 3. Turn the gas oil mixture of

POWER
 STOP
 START

Easy
START-UP
 GUIDE
 Included



16" 37CC
GAS CHAIN SAW



16" 37CC
GAS CHAIN SAW